

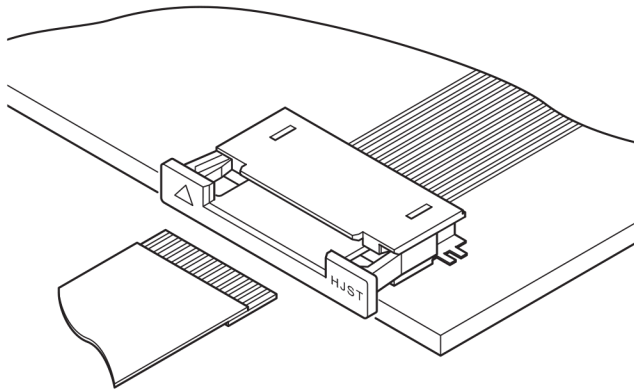

# FLZ CONNECTOR

0.5mm pitch/Connectors for FFC and FPC



**This extremely small 0.5mm pitch connector with a height of only 2.0mm above the PCB surface allows interconnection in extremely small spaces and is an example of JST's leading edge technology.**

- Zero insertion force mechanism
- Heat resisting design suitable for surface mounting
- In-line surface mount tails
- Two types of connections
- Embossed tape for automatic mounting

## Specifications

- Current rating: 0.5 A AC, DC
- Voltage rating: 50 V AC, DC
- Temperature range: -25°C to +85°C  
(including temperature rise in applying electrical current)
- Contact resistance: Initial value/ 40 mΩ max.  
After environmental tests/ 60 mΩ max.
- Insulation resistance: 800 MΩ min.
- Withstanding voltage: 200 VAC/minute
- Applicable FFC and FPC: Conductor pitch/ 0.5 mm  
Conductor width/ 0.35 mm  
Mating part thickness/ 0.3 ± 0.03 mm

Note: FFC and FPC to be actually used should be checked for applicability.

- \* Refer to "General Instruction and Notice when using Terminals and Connectors" at the end of this catalog.
- \* Contact JST for details.
- \* Compliant with RoHS.

## Standards

Recognized E60389

Certified LR20812

## PC board layout and Assembly layout

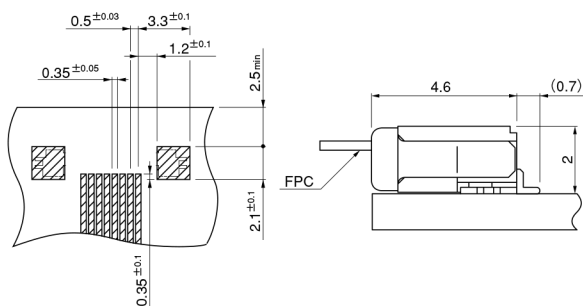

### Inner lock type

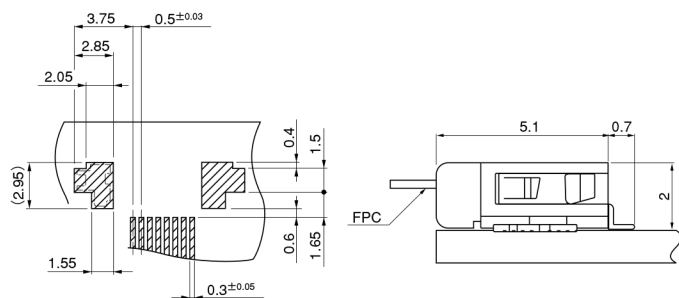

Note: 1. The above figure is the figure viewed from the connector mounting side.  
2. Tolerances are non-cumulative: ±0.03 mm for all centers.  
3. The dimensions above should serve as a guideline. Contact JST for details.

# FLZ CONNECTOR

## Connector

### Normal type

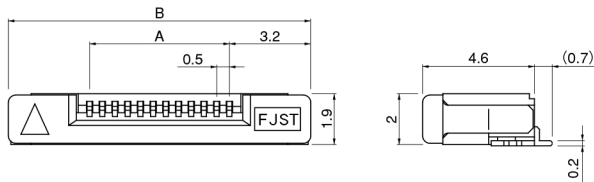

### Reverse type

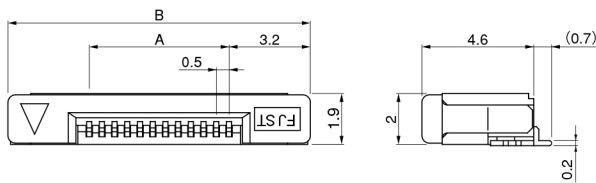

### <Inner lock type>

#### Normal type

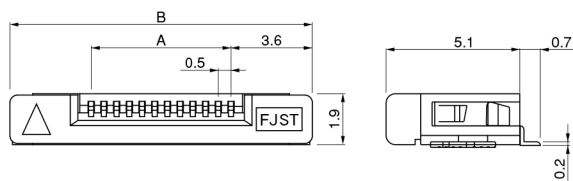

#### Reverse type

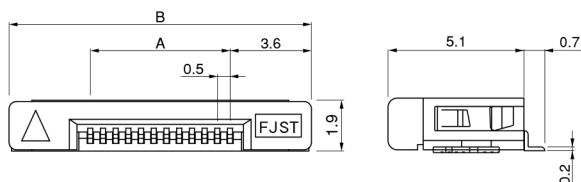

Circuits	Model No.		Dimensions (mm)		Q'ty/ reel
	Normal type	Reverse type	A	B	
6	06FLZ-SM2-TB	06FLZ-RSM2-TB	2.5	8.9	2,800
7	07FLZ-SM2-TB	07FLZ-RSM2-TB	3.0	9.4	2,800
8	08FLZ-SM2-TB	08FLZ-RSM2-TB	3.5	9.9	2,800
9	09FLZ-SM2-TB	09FLZ-RSM2-TB	4.0	10.4	2,800
10	10FLZ-SM2-TB	10FLZ-RSM2-TB	4.5	10.9	2,800
11	11FLZ-SM2-TB	11FLZ-RSM2-TB	5.0	11.4	2,800
12	12FLZ-SM2-TB	12FLZ-RSM2-TB	5.5	11.9	2,800
13	13FLZ-SM2-TB	13FLZ-RSM2-TB	6.0	12.4	2,800
14	14FLZ-SM2-TB	14FLZ-RSM2-TB	6.5	12.9	2,800
15	15FLZ-SM2-TB	15FLZ-RSM2-TB	7.0	13.4	2,800
16	16FLZ-SM2-TB	16FLZ-RSM2-TB	7.5	13.9	2,800
17	17FLZ-SM2-TB	17FLZ-RSM2-TB	8.0	14.4	2,800
18	18FLZ-SM2-TB	18FLZ-RSM2-TB	8.5	14.9	2,800
19	19FLZ-SM2-TB	19FLZ-RSM2-TB	9.0	15.4	2,800
20	20FLZ-SM2-TB	20FLZ-RSM2-TB	9.5	15.9	2,800
21	21FLZ-SM2-TB	21FLZ-RSM2-TB	10.0	16.4	2,800
22	22FLZ-SM2-TB	22FLZ-RSM2-TB	10.5	16.9	2,800
23	23FLZ-SM2-TB	23FLZ-RSM2-TB	11.0	17.4	2,800
24	24FLZ-SM2-TB	24FLZ-RSM2-TB	11.5	17.9	2,800
25	25FLZ-SM2-TB	25FLZ-RSM2-TB	12.0	18.4	2,800
26	26FLZ-SM2-TB	26FLZ-RSM2-TB	12.5	18.9	2,800
27	27FLZ-SM2-TB	27FLZ-RSM2-TB	13.0	19.4	2,800
28	28FLZ-SM2-TB	28FLZ-RSM2-TB	13.5	19.9	2,800
30	30FLZ-SM2-TB	30FLZ-RSM2-TB	14.5	20.9	2,800
33	33FLZ-SM2-TB	—	16.0	22.4	2,800

### <Inner lock type>

Circuits	Model No.		Dimensions (mm)		Q'ty/ reel
	Normal type	Reverse type	A	B	
13	—	13FLZ-RSM2-R-TB	6.0	13.1	2,800
30	30FLZ-SM2-R-TB	—	14.5	21.6	2,800
32	32FLZ-SM2-R-TB	32FLZ-RSM2-R-TB	15.5	22.6	2,800
34	34FLZ-SM2-R-TB	34FLZ-RSM2-R-TB	16.5	23.6	2,800
36	36FLZ-SM2-R-TB	36FLZ-RSM2-R-TB	17.5	24.6	2,800
40	40FLZ-SM2-R-TB	40FLZ-RSM2-R-TB	19.5	26.6	2,800
42	42FLZ-SM2-R-TB	—	20.5	27.6	2,800
45	45FLZ-SM2-R-TB	—	22.0	29.1	2,800
50	50FLZ-SM2-R-TB	—	24.5	31.6	2,800

#### Material and Finish

Contact: Phosphor bronze, copper-undercoated, tin-plated (reflow treatment)  
 Slider housing: PA 6T, UL94V-0 (black)  
 Housing: PA 6T, UL94V-0  
 Normal type...gray  
 Reverse type...natural  
 Solder tab: Phosphor bronze, copper-undercoated, tin-plated (reflow treatment)

**RoHS compliance** This product displays (LF)(SN) on a label.  
 Note: The products listed above are supplied on embossed tape.

## Lead section dimensions of FFC and FPC

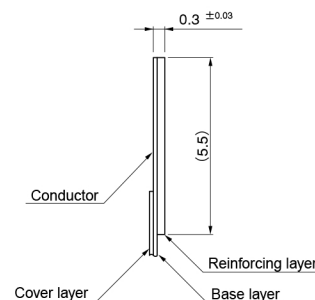
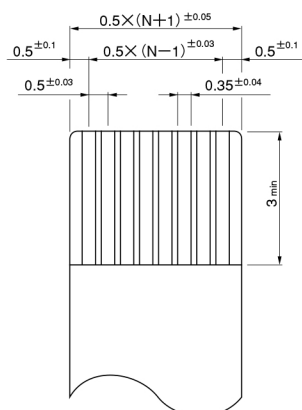

Note: N --- Number of circuits