

PERFECT Kabelverschraubung

50.6xx PAzzzz/zXz

Hutmutter	Polyamid PA6 V-2
Dichteinsatz	TPE TPS
Zwischenstutzen	Polyamid PA6 V-2
Anschlussgewinde	metrisch, nach EN 60423



Eigenschaften

Temperaturbereich	<ul style="list-style-type: none"> Dichteinsatz zur Durchführung mehrerer Einzelkabel -20 °C / +100 °C (dynamisch) -40 °C (statisch, kurzzeitig)
Schutzart	max. IP65 wenn Kabel Ø = Loch Ø
Hinweis	bitte den gewünschten Dichteinsatz angeben, z.B. 50.612 PA/4x2 Dichteinsätze - siehe unter Zubehör - Serie WJ-DM xx/zXz, Katalog Seite 203

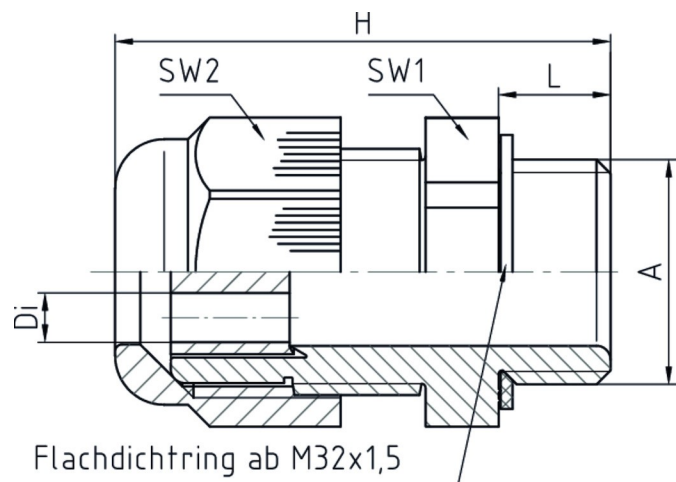

Merkmale



RAL 9005

Anschlussgewinde Standardlänge

A	L	SW1	SW2	H	VPE	Art.-Nr.
M12x1,5	8	15	15	31	100	50.612PA/SW/zXz
M16x1,5	8	20	20	35,5	100	50.616PA/SW/zXz
M20x1,5	8	24	24	36	100	50.620PA/SW/zXz
M25x1,5	8	29	29	43	50	50.625PA/SW/zXz
M32x1,5	10	36	36	50	25	50.632PA/SW/zXz
M40x1,5	10	46	46	51	10	50.640PA/SW/zXz



RAL 7035

Anschlussgewinde Standardlänge

A	L	SW1	SW2	H	 VPE	Art.-Nr.
M12x1,5	8	15	15	31	100	50612PA7035/zXz
M16x1,5	8	20	20	35,5	100	50616PA7035/zXz
M20x1,5	8	24	24	36	100	50620PA7035/zXz
M25x1,5	8	29	29	43	50	50625PA7035/zXz
M32x1,5	10	36	36	50	25	50632PA7035/zXz
M40x1,5	10	46	46	51	10	50640PA7035/zXz



RAL 7001

Anschlussgewinde Standardlänge

A	L	SW1	SW2	H	 VPE	Art.-Nr.
M12x1,5	8	15	15	31	100	50.612 PA/zXz
M16x1,5	8	20	20	35,5	100	50.616 PA/zXz
M20x1,5	8	24	24	36	100	50.620 PA/zXz
M25x1,5	8	29	29	43	50	50.625 PA/zXz
M32x1,5	10	36	36	50	25	50.632 PA/zXz
M40x1,5	10	46	46	51	10	50.640 PA/zXz