

Features

- Han-Modular® docking connector for drawer systems
- Highest flexibility due to a product range of over 100 connector modules
- Direct panel mounting without housing
- Solid pre-leading guide pins and bushes
- The docking frame has no PE contact as it is not required in many drawer system applications. However earthing can be realised, if necessary, with the aid of the Han-Modular® PE module.

Note:



Suitable for most of the Han-Modular® modules except for Han® Megabit module

Technical characteristics

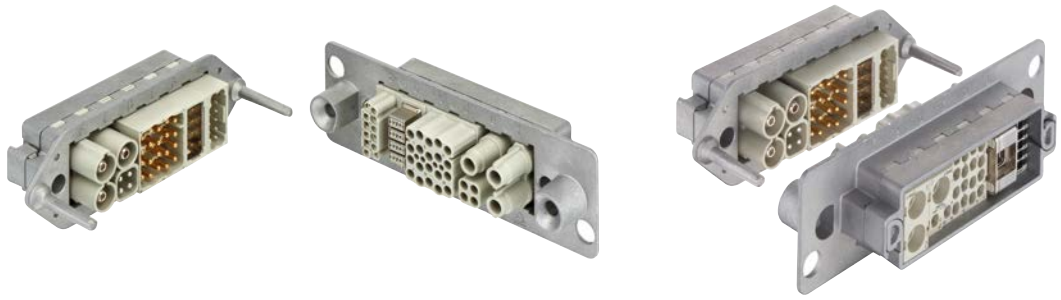
Specifications	DIN EN 60664-1 DIN EN 61984
Frames	
Number of modules	2, 4, 6
Material	
Docking Frames	zinc die-cast alloy
Float washer	zinc die-cast alloy
Floating tolerance	± 2 mm
Aligning tolerance	± 4 mm
Limiting temperatures	-40 °C ... +125 °C
Flammability acc. to UL 94	V 0
Mechanical working life	≥ 500 mating cycles ≥ 10 000 mating cycles with other HMC components

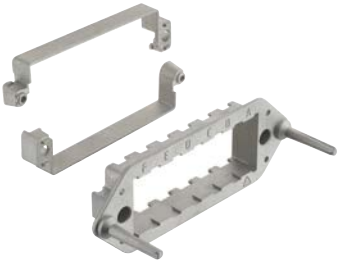
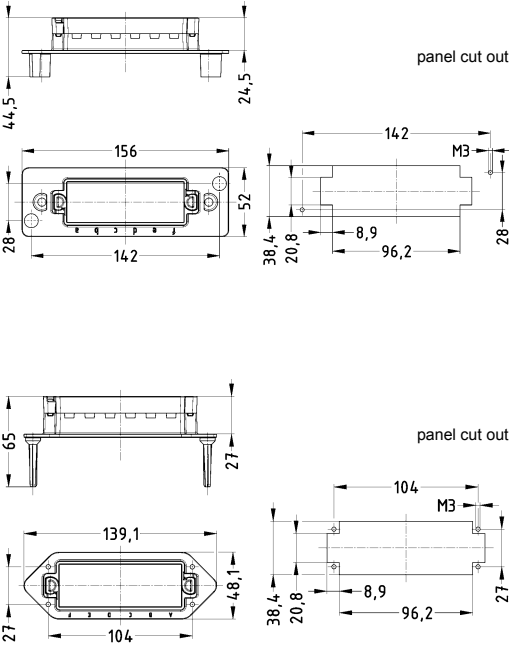

Identification	Float mount	Fixed	Drawings	Dimensions in mm
<p>Docking frames for 2 modules</p>	<p>marking a ... b</p> <p>09 14 006 1706</p>			<p>panel cut out</p>
<p>Docking frames for 2 modules</p>		<p>marking A ... B</p> <p>09 14 006 1716</p>		<p>panel cut out</p>
<p>Docking frames for 4 modules</p>	<p>marking a ... d</p> <p>09 14 016 1706</p>			<p>panel cut out</p>
<p>Docking frames for 4 modules</p>		<p>marking A ... D</p> <p>09 14 016 1716</p>		<p>panel cut out</p>

Identification	Float mount	Fixed	Drawings	Dimensions in mm
<p>Docking frames for 6 modules</p>  <p>Docking frames for 6 modules</p> 	<p>marking a ... f</p> <p>09 14 024 1706</p>	<p>marking A ... F</p> <p>09 14 024 1716</p>		
<p>Float washer for float mounting of the sliding frame 09 14 0xx 1706</p> 	<p>09 14 000 9936</p>		